



ZEUS[®]

HEAT SHRINKABLE EXTRUSIONS



HEAT SHRINKABLE EXTRUSIONS





ZEUS

Heat Shrink Fluoropolymer Tubing

WWW.ZEUSINC.COM

HEAT SHRINKABLE EXTRUSIONS

ZEUS heat shrink tubing offers a unique combination of properties in its tubing, including outstanding electrical characteristics; excellent chemical and solvent resistances; purity; lubricity and outstanding performance reliability.



ZEUS has mastered the art of manufacturing fluoropolymer heat shrink tubing and can supply it with recovered walls as thin as .002". Please contact a ZEUS representative to learn more about customer sizes, packaging, lengths and colors.

Heat Shrink Application Tips

1. Always assure good ventilation in the immediate work area prior to beginning the heat shrinking process.

Caution: Fumes may cause nausea and dizziness.

2. The mandrel to be covered by the heat shrink must be able to withstand the required temperature for material recovery (see table at right).
3. The mandrel being covered may act as a heat sink (especially metal mandrels). Therefore, ZEUS recommends preheating mandrels.
4. Heat shrink should be allowed to recover a minimum of 20%. Highly restricted radial recovery tends to induce longitudinal change and increase the tendency for splitting.

TOP VIEW - ROLLER IN LATHE

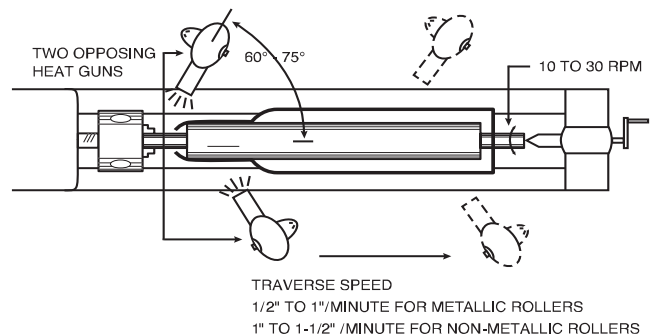

SAME PROCEDURE APPLIES FOR MANUAL ROTATION

5. Ovens are the most reliable way to recover heat shrink products due to their ability to ensure even heating and reduce the risk of over heating the material which can lead to brittleness and cracking. If a heat gun will be used please refer to the picture above illustrating the proper application of heat to achieve the most uniform recovery.
6. See Chart for recovery temperatures.

HEAT SHRINK RECOVERY TEMPERATURE

Material	Recovery Temperature
PTFE	654°F - 670°F 346°C - 354°C
FEP (1" ID or less)	400°F - 420°F 204°C - 216°C
FEP (1" ID or greater)	420°F - 440°F 216°C - 227°C

The heat shrink temperatures listed in this catalog are general guidelines. Actual shrink temperatures may be higher or lower depending on the design and dimensions of the heat shrink, application techniques and other factors. Please contact a ZEUS Technical Account Manager for more information.



PTFE Heat Shrink

2 to 1 Shrink Ratio

Approximate Ratio of Expanded I.D. to Recovered I.D. – AWG Sizes

WWW.ZEUSINC.COM

HEAT SHRINKABLE EXTRUSIONS

Dimensions (inches)



STANDARD WALL, Class 2					THIN WALL, Class 3					LIGHTWEIGHT WALL, Class 4				
Ordered as AWG Size No.	Expanded I.D. Min.	Recovered I.D. Max.	Recovered Wall Thickness		Ordered as AWG Size No.	Expanded I.D. Min.	Recovered I.D. Max.	Recovered Wall Thickness		Ordered as AWG Size No.	Expanded I.D. Min.	Recovered I.D. Max.	Recovered Wall Thickness	
			Nom.	Tol.				Nom.	Tol.				Nom.	Tol.
30*	0.034	0.015	0.009	±.002	30	0.034	0.015	0.009	±.002	30*	0.034	0.015	0.006	±.002
28*	0.038	0.018	0.009	±.002	28	0.038	0.018	0.009	±.002	28*	0.038	0.018	0.006	±.002
26*	0.046	0.022	0.010	±.002	26	0.046	0.022	0.010	±.002	26*	0.046	0.022	0.006	±.002
24	0.050	0.027	0.012	±.002	24	0.050	0.027	0.010	±.002	24	0.050	0.025	0.006	±.002
22	0.055	0.032	0.012	±.002	22	0.055	0.032	0.012	±.003	22	0.055	0.031	0.006	±.002
20	0.060	0.039	0.016	±.003	20	0.060	0.039	0.012	±.003	20	0.060	0.038	0.006	±.002
19	0.065	0.043	0.016	±.003	19	0.065	0.043	0.012	±.003	19	0.065	0.043	0.006	±.002
18	0.076	0.049	0.016	±.003	18	0.076	0.049	0.012	±.003	18	0.076	0.046	0.006	±.002
17	0.085	0.054	0.016	±.003	17	0.085	0.054	0.012	±.003	17	0.085	0.054	0.006	±.002
16	0.093	0.061	0.016	±.003	16	0.093	0.061	0.012	±.003	16	0.093	0.057	0.006	±.002
15	0.110	0.067	0.016	±.003	15	0.110	0.067	0.012	±.003	15	0.110	0.063	0.006	±.002
14	0.120	0.072	0.016	±.003	14	0.120	0.072	0.012	±.003	14	0.120	0.072	0.008	±.002
13	0.140	0.080	0.016	±.003	13	0.140	0.080	0.012	±.003	13	0.140	0.080	0.008	±.002
12	0.150	0.089	0.016	±.003	12	0.150	0.089	0.012	±.003	12	0.150	0.089	0.008	±.002
11	0.170	0.101	0.016	±.003	11	0.170	0.101	0.012	±.003	11	0.170	0.099	0.008	±.002
10	0.191	0.112	0.016	±.003	10	0.191	0.112	0.012	±.003	10	0.191	0.110	0.008	±.002
9	0.205	0.124	0.020	±.004	9	0.205	0.124	0.015	±.004	9	0.205	0.122	0.008	±.002
8	0.240	0.141	0.020	±.004	8	0.240	0.141	0.015	±.004	8	0.240	0.139	0.008	±.002
7	0.270	0.158	0.020	±.004	7	0.270	0.158	0.015	±.004	7	0.270	0.154	0.008	±.002
6	0.302	0.178	0.020	±.004	6	0.302	0.178	0.015	±.004	6	0.302	0.172	0.010	±.003
5	0.320	0.198	0.020	±.004	5	0.320	0.198	0.015	±.004	5	0.320	0.192	0.010	±.003
4	0.370	0.224	0.020	±.004	4	0.370	0.224	0.015	±.004	4	0.370	0.214	0.010	±.003
3	0.390	0.249	0.020	±.004	3	0.390	0.249	0.015	±.004	3	0.390	0.241	0.010	±.003
2	0.430	0.278	0.020	±.004	2	0.430	0.278	0.015	±.004	2	0.430	0.270	0.010	±.003
1	0.450	0.311	0.020	±.004	1	0.450	0.311	0.015	±.004	1	0.450	0.301	0.010	±.003
0	0.470	0.347	0.020	±.004	0	0.470	0.347	0.015	±.004	0	0.470	0.347	0.012	±.003

AMS-DTL-23053/12

*AWG 30, 28, 26 SW and LW are not covered under AMS-DTL-23053/12.

PACKAGING: Standard 4ft lengths, unless otherwise specified.

On all cases of military or commercial specifications, latest revisions apply. Supplied in natural unless otherwise specified. Custom Pantone colors or ZEUS standard colors available on request.



PTFE Heat Shrink

2 to 1 Shrink Ratio

Approximate Ratio of Expanded I.D. to Recovered I.D. – AWG Sizes

WWW.ZEUSINC.COM

HEAT SHRINKABLE EXTRUSIONS

Metric Dimensions (mm)

Custom Sizes Available

STANDARD WALL					THIN WALL					LIGHTWEIGHT WALL				
Ordered as AWG Size No.	Expanded I.D. Min.	Recovered I.D. Max.	Recovered Wall Thickness Nom.	Recovered Wall Thickness Tol.	Ordered as AWG Size No.	Expanded I.D. Min.	Recovered I.D. Max.	Recovered Wall Thickness Nom.	Recovered Wall Thickness Tol.	Ordered as AWG Size No.	Expanded I.D. Min.	Recovered I.D. Max.	Recovered Wall Thickness Nom.	Recovered Wall Thickness Tol.
30*	0.86	0.38	0.23	±.05	30	0.86	0.38	0.23	±.05	30*	0.86	0.38	0.15	±.05
28*	0.96	0.46	0.23	±.05	28	0.96	0.46	0.23	±.05	28*	0.96	0.46	0.15	±.05
26*	1.17	0.56	0.25	±.05	26	1.17	0.56	0.25	±.05	26*	1.17	0.56	0.15	±.05
24	1.27	0.69	0.30	±.05	24	1.27	0.69	0.25	±.05	24	1.27	0.64	0.15	±.05
22	1.40	0.81	0.30	±.05	22	1.40	0.81	0.30	±.08	22	1.40	0.79	0.15	±.05
20	1.52	0.99	0.41	±.08	20	1.52	0.99	0.30	±.08	20	1.52	0.97	0.15	±.05
19	1.65	1.09	0.41	±.08	19	1.65	1.09	0.30	±.08	19	1.65	1.09	0.15	±.05
18	1.93	1.24	0.41	±.08	18	1.93	1.24	0.30	±.08	18	1.93	1.17	0.15	±.05
17	2.16	1.37	0.41	±.08	17	2.16	1.37	0.30	±.08	17	2.16	1.37	0.15	±.05
16	2.36	1.55	0.41	±.08	16	2.36	1.55	0.30	±.08	16	2.36	1.45	0.15	±.05
15	2.79	1.70	0.41	±.08	15	2.79	1.70	0.30	±.08	15	2.79	1.60	0.15	±.05
14	3.05	1.83	0.41	±.08	14	3.05	1.83	0.30	±.08	14	3.05	1.83	0.20	±.05
13	3.56	2.03	0.41	±.08	13	3.56	2.03	0.30	±.08	13	3.56	2.03	0.20	±.05
12	3.81	2.26	0.41	±.08	12	3.81	2.26	0.30	±.08	12	3.81	2.26	0.20	±.05
11	4.32	2.57	0.41	±.08	11	4.32	2.57	0.30	±.08	11	4.32	2.51	0.20	±.05
10	4.85	2.84	0.41	±.08	10	4.85	2.84	0.30	±.08	10	4.85	2.79	0.20	±.05
9	5.21	3.15	0.51	±.10	9	5.21	3.15	0.38	±.10	9	5.21	3.10	0.20	±.05
8	6.10	3.58	0.51	±.10	8	6.10	3.58	0.38	±.10	8	6.10	3.53	0.20	±.05
7	6.86	4.01	0.51	±.10	7	6.86	4.01	0.38	±.10	7	6.86	3.91	0.20	±.05
6	7.67	4.52	0.51	±.10	6	7.67	4.52	0.38	±.10	6	7.67	4.37	0.25	±.08
5	8.13	5.03	0.51	±.10	5	8.13	5.03	0.38	±.10	5	8.13	4.88	0.25	±.08
4	9.40	5.69	0.51	±.10	4	9.40	5.69	0.38	±.10	4	9.40	5.44	0.25	±.08
3	9.91	6.32	0.51	±.10	3	9.91	6.32	0.38	±.10	3	9.91	6.12	0.25	±.08
2	10.92	7.06	0.51	±.10	2	10.92	7.06	0.38	±.10	2	10.92	6.86	0.25	±.08
1	11.43	7.90	0.51	±.10	1	11.43	7.90	0.38	±.10	1	11.43	7.65	0.25	±.08
0	11.94	8.81	0.51	±.10	0	11.94	8.81	0.38	±.10	0	11.94	8.81	0.30	±.08

AMS-DTL-23053/12

*AWG 30, 28, 26 SW and LW are not covered under AMS-DTL-23053/12.

PACKAGING: Standard 4ft lengths, unless otherwise specified.

Custom Pantone colors or ZEUS standard colors available on request.



PTFE Heat Shrink

2 to 1 Shrink Ratio

Approximate Ratio of Expanded I.D. to Recovered I.D. – Fractional Inch Sizes

WWW.ZEUSINC.COM

HEAT SHRINKABLE EXTRUSIONS



Dimensions (inches)

STANDARD WALL, Class 2					THIN WALL, Class 3					INDUSTRIAL WALL, Class 1				
Ordered as ID	Expanded I.D. Min.	Recovered I.D. Max.	Recovered Wall Thickness		Ordered as ID	Expanded I.D. Min.	Recovered I.D. Max.	Recovered Wall Thickness		Ordered as ID	Expanded I.D. Min.	Recovered I.D. Max.	Recovered Wall Thickness	
			Nom.	Tol.				Nom.	Tol.				Nom.	Tol.
1/8	0.215	0.130	0.020	±.004	1/8	0.215	0.130	0.015	±.003	1/8	0.166	0.130	0.030	±.005
1/4	0.410	0.260	0.020	±.004	1/4	0.410	0.260	0.015	±.003	3/16	0.250	0.193	0.030	±.005
5/16	0.470	0.329	0.020	±.004	5/16	0.470	0.329	0.015	±.003	1/4	0.333	0.257	0.030	±.005
3/8	0.560	0.399	0.025	±.006	3/8	0.560	0.399	0.015	±.003	5/16	0.415	0.320	0.030	±.005
7/16	0.655	0.462	0.025	±.006	7/16	0.655	0.462	0.018	±.004	3/8	0.498	0.383	0.030	±.005
1/2	0.750	0.524	0.025	±.006	1/2	0.750	0.524	0.018	±.004	7/16	0.580	0.448	0.030	±.006
5/8	0.930	0.655	0.030	±.006	5/8	0.930	0.655	0.020	±.004	1/2	0.666	0.510	0.030	±.006
3/4	1.125	0.786	0.035	±.008	3/4	1.125	0.786	0.025	±.005	9/16	0.748	0.572	0.030	±.006
7/8	1.310	0.911	0.035	±.008	7/8	1.310	0.911	0.030	±.006	5/8	0.830	0.637	0.030	±.006
1	1.500	1.036	0.035	±.008	1	1.500	1.036	0.030	±.006	11/16	0.915	0.700	0.032	±.006
										3/4	1.000	0.764	0.040	±.007
										7/8	1.170	0.891	0.045	±.007
										1	1.330	1.020	0.050	±.008

LIGHTWEIGHT WALL, Class 4				
Ordered as ID	Expanded I.D. Min.	Recovered I.D. Max.	Recovered Wall Thickness	
			Nom.	Tol.
1/8	0.215	0.130	0.008	±.002
1/4	0.410	0.260	0.010	±.003
5/16	0.470	0.329	0.012	±.003



PTFE Heat Shrink

2 to 1 Shrink Ratio

Approximate Ratio of Expanded I.D. to Recovered I.D. – Fractional Inch Sizes

WWW.ZEUSINC.COM

HEAT SHRINKABLE EXTRUSIONS

Metric Dimensions (mm)

Custom Sizes Available

STANDARD WALL, Class 2					THIN WALL, Class 3					INDUSTRIAL WALL, Class 1				
Ordered as ID	Expanded I.D. Min.	Recovered I.D. Max.	Recovered Wall Thickness Nom.	Recovered Wall Thickness Tol.	Ordered as ID	Expanded I.D. Min.	Recovered I.D. Max.	Recovered Wall Thickness Nom.	Recovered Wall Thickness Tol.	Ordered as ID	Expanded I.D. Min.	Recovered I.D. Max.	Recovered Wall Thickness Nom.	Recovered Wall Thickness Tol.
1/8	5.46	3.30	0.51	±.10	1/8	5.46	3.30	0.38	±.08	1/8	4.22	3.30	0.76	±.13
1/4	10.41	6.60	0.51	±.10	1/4	10.41	6.60	0.38	±.08	3/16	6.35	4.90	0.76	±.13
5/16	11.94	8.36	0.51	±.10	5/16	11.94	8.36	0.38	±.08	1/4	8.46	6.53	0.76	±.13
3/8	14.22	10.13	0.64	±.15	3/8	14.22	10.13	0.38	±.08	5/16	10.54	8.13	0.76	±.13
7/16	16.64	11.73	0.64	±.15	7/16	16.64	11.73	0.46	±.10	3/8	12.65	9.73	0.76	±.13
1/2	19.05	13.31	0.64	±.15	1/2	19.05	13.31	0.46	±.10	7/16	14.73	11.38	0.76	±.15
5/8	23.62	16.64	0.76	±.15	5/8	23.62	16.64	0.51	±.10	1/2	16.92	12.95	0.76	±.15
3/4	28.58	19.96	0.89	±.20	3/4	28.58	19.96	0.64	±.13	9/16	19.00	14.53	0.76	±.15
7/8	33.27	23.14	0.89	±.20	7/8	33.27	23.14	0.76	±.15	5/8	21.08	16.18	0.76	±.15
1	38.10	26.31	0.89	±.20	1	38.10	26.31	0.76	±.15	11/16	23.24	17.78	0.81	±.15
										3/4	25.40	19.41	1.02	±.18
										7/8	29.72	22.63	1.14	±.18
										1	33.78	25.91	1.27	±.20

LIGHTWEIGHT WALL, Class 4

Ordered as ID	Expanded I.D. Min.	Recovered I.D. Max.	Recovered Wall Thickness Nom.	Recovered Wall Thickness Tol.
1/8	5.46	3.30	0.20	±.05
1/4	10.41	6.60	0.25	±.07
5/16	11.94	8.36	0.30	±.07



PTFE Heat Shrink

4 to 1 Shrink Ratio

Approximate Ratio of Expanded I.D. to Recovered I.D. – Fractional Inch Sizes

WWW.ZEUSINC.COM

HEAT SHRINKABLE EXTRUSIONS

Dimensions (inches)

Ordered As Fractional I.D.	Expanded I.D.	RECOVERED – AFTER HEAT SHRINK		
		I.D. Max.	Wall Thickness Nom.	Tol.
5/64	0.078	0.025	0.009	±.002
1/8	0.125	0.037	0.012	±.002
3/16	0.187	0.050	0.012	±.002
1/4	0.250	0.063	0.012	±.002
5/16	0.312	0.078	0.012	±.002
3/8	0.375	0.096	0.012	±.002
7/16	0.438	0.112	0.012	±.002
1/2	0.500	0.144	0.015	±.004
9/16	0.562	0.155	0.015	±.004
5/8	0.625	0.178	0.015	±.004
11/16	0.687	0.198	0.015	±.004
3/4	0.750	0.224	0.015	±.004
7/8	0.875	0.244	0.015	±.004
1	1.000	0.278	0.015	±.004
1-1/4	1.250	0.347	0.015	±.004
1-1/2	1.500	0.400	0.015	±.004
1-3/4	1.750	0.450	0.015	±.004
2	2.000	0.520	0.020	±.005
2-1/4	2.250	0.585	0.020	±.005
2-1/2	2.500	0.650	0.020	±.005
2-3/4	2.750	0.710	0.020	±.005
3	3.000	0.775	0.020	±.005
3-1/4	3.250	0.835	0.020	±.005
3-1/2	3.500	0.900	0.025	±.005
3-3/4	3.750	0.960	0.025	±.005
4	4.000	1.025	0.025	±.005

Metric Dimensions (mm)



Ordered As Fractional I.D.	Expanded I.D.	RECOVERED – AFTER HEAT SHRINK		
		I.D. Max.	Wall Thickness Nom.	Tol.
5/64	1.98	0.64	0.23	±.05
1/8	3.18	0.94	0.31	±.05
3/16	4.75	1.27	0.31	±.05
1/4	6.35	1.60	0.31	±.05
5/16	7.92	1.98	0.31	±.05
3/8	9.53	2.44	0.31	±.05
7/16	11.13	2.84	0.31	±.05
1/2	12.70	3.66	0.38	±.10
9/16	14.27	3.94	0.38	±.10
5/8	15.88	4.52	0.38	±.10
11/16	17.45	5.03	0.38	±.10
3/4	19.05	5.69	0.38	±.10
7/8	22.23	6.20	0.38	±.10
1	25.40	7.06	0.38	±.10
1-1/4	31.75	8.81	0.38	±.10
1-1/2	38.10	10.16	0.38	±.10
1-3/4	44.45	11.43	0.38	±.10
2	50.80	13.21	0.51	±.13
2-1/4	57.15	14.86	0.51	±.13
2-1/2	63.50	16.51	0.51	±.13
2-3/4	69.85	18.03	0.51	±.13
3	76.20	19.68	0.51	±.13
3-1/4	82.50	21.21	0.51	±.13
3-1/2	88.90	22.86	0.64	±.13
3-3/4	92.95	24.38	0.64	±.13
4	101.60	26.03	0.64	±.13

Custom Pantone colors or ZEUS standard colors available on request.
Complies with AMS-DTL-23053/12. Class 5.



FEP Heat Shrink

1.3 to 1 Shrink Ratio

Approximate Ratio of Expanded I.D. to Recovered I.D. – AWG/Fractional Inch Sizes

WWW.ZEUSINC.COM

HEAT SHRINKABLE EXTRUSIONS

Dimensions (inches)



Ordered as AWG Size	As Supplied Inside Diameter Min.	Recovered – After Shrinking			
		I.D. Will Shrink to at Least	Min.	Wall Thickness Nom.	Max.
24	0.031	0.027	0.006	0.008	0.010
22	0.036	0.032	0.006	0.008	0.010
20	0.045	0.039	0.006	0.008	0.010
18	0.060	0.049	0.006	0.008	0.010
16	0.075	0.061	0.007	0.009	0.011
14	0.092	0.072	0.007	0.009	0.011
12	0.115	0.089	0.007	0.009	0.011
10	0.141	0.114	0.007	0.010	0.013
9	0.158	0.124	0.007	0.010	0.013
8	0.180	0.143	0.007	0.010	0.013
7	0.197	0.158	0.007	0.011	0.015
6	0.225	0.180	0.007	0.011	0.015
5	0.248	0.198	0.007	0.011	0.015
4	0.290	0.226	0.007	0.011	0.015
3	0.310	0.249	0.007	0.011	0.015
2	0.365	0.280	0.008	0.012	0.016
1	0.400	0.311	0.008	0.012	0.016
0	0.440	0.349	0.008	0.012	0.016

Fractional Inch (decimal) Tubing

Size	As Supplied Inside Diameter Min.	Recovered – After Shrinking			
		I.D. Will Shrink to at Least	Min.	Wall Thickness Nom.	Max.
3/8 (0.375)	0.500	0.383	0.011	0.015	0.019
7/16 (0.438)	0.580	0.448	0.016	0.020	0.024
1/2 (0.500)	0.666	0.510	0.016	0.020	0.024
5/8 (0.625)	0.830	0.637	0.021	0.025	0.029
3/4 (0.750)	1.000	0.764	0.026	0.030	0.034
7/8 (0.875)	1.170	0.891	0.031	0.035	0.039
1 (1.000)	1.330	1.020	0.031	0.035	0.039
1-1/8 (1.125)	1.500	1.145	0.031	0.035	0.039
1-1/4 (1.250)	1.666	1.270	0.031	0.035	0.039
1-3/8 (1.375)	1.833	1.390	0.031	0.035	0.039
1-1/2 (1.500)	2.000	1.570	0.031	0.035	0.039

COMPLIES WITH: AMS-DTL-23053/11Class 1

COLOR: Supplied in natural unless otherwise specified. Custom Pantone colors or ZEUS standard colors available on request.

CUSTOM SPECIFICATIONS AND TOLERANCES QUOTED UPON REQUEST



FEP Heat Shrink

1.3 to 1 Shrink Ratio

Approximate Ratio of Expanded I.D. to Recovered I.D. – AWG/Fractional Inch Sizes

WWW.ZEUSINC.COM

HEAT SHRINKABLE EXTRUSIONS



Metric Dimensions (mm)

Ordered as AWG Size	As Supplied Inside Diameter Min.	Recovered – After Shrinking			
		I.D. Will Shrink to at Least	Min.	Wall Thickness Nom.	Max.
24	0.79	0.69	0.15	0.20	0.25
22	0.91	0.81	0.15	0.20	0.25
20	1.14	0.99	0.15	0.20	0.25
18	1.52	1.25	0.15	0.20	0.25
16	1.91	1.55	0.18	0.23	0.28
14	2.34	1.83	0.18	0.23	0.28
12	2.92	2.26	0.18	0.23	0.28
10	3.58	2.90	0.18	0.25	0.33
9	4.01	3.15	0.18	0.25	0.33
8	4.57	3.63	0.18	0.25	0.33
7	5.00	4.01	0.18	0.28	0.38
6	5.72	4.57	0.18	0.28	0.38
5	6.30	5.03	0.18	0.28	0.38
4	7.37	5.74	0.18	0.28	0.38
3	7.87	6.32	0.18	0.28	0.38
2	9.27	7.11	0.20	0.30	0.41
1	10.16	7.90	0.20	0.30	0.41
0	11.18	8.86	0.20	0.30	0.41

Fractional Inch (mm) Tubing

Size	As Supplied Inside Diameter Min.	Recovered – After Shrinking			
		I.D. Will Shrink to at Least	Min.	Wall Thickness Nom.	Max.
3/8 (9.53)	12.70	9.73	0.28	0.38	0.48
7/16 (11.13)	14.73	11.38	0.41	0.51	0.61
1/2 (12.70)	16.92	12.95	0.41	0.51	0.61
5/8 (15.88)	21.08	16.18	0.53	0.64	0.74
3/4 (19.05)	25.40	19.41	0.66	0.76	0.86
7/8 (22.23)	29.72	22.63	0.79	0.89	0.99
1 (25.40)	33.78	25.91	0.79	0.89	0.99
1-1/8 (28.58)	38.10	29.08	0.79	0.89	0.99
1-1/4 (31.75)	42.32	32.26	0.79	0.89	0.99
1-3/8 (34.93)	46.56	35.31	0.79	0.89	0.99
1-1/2 (38.10)	50.80	39.88	0.79	0.89	0.99

COMPLIES WITH: AMS-DTL-23053/11 Class 1

COLOR: Supplied in natural unless otherwise specified. Custom Pantone colors or ZEUS standard colors available on request.

CUSTOM SPECIFICATIONS AND TOLERANCES QUOTED UPON REQUEST



WWW.ZEUSINC.COM

FEP Heat Shrink

1.6 to 1 Shrink Ratio

HEAT SHRINKABLE EXTRUSIONS



Dimensions (inches)

Fractional	Size		Expanded I.D. Minimum	Recovered I.D. Maximum	Wall Thickness	
	Decimal				Nom.	Tol.
3/32		0.093	0.093	0.056	0.008	±0.003
1/8		0.125	0.125	0.075	0.010	±0.003
3/16		0.188	0.188	0.115	0.010	±0.003
1/4		0.250	0.250	0.150	0.010	±0.003
3/8		0.375	0.375	0.225	0.012	±0.003
1/2		0.500	0.500	0.300	0.015	±0.004
3/4		0.750	0.750	0.450	0.020	±0.004
1		1.000	1.000	0.600	0.025	±0.005
1-1/2		1.500	1.500	0.900	0.030	±0.005
2		2.000	2.000	1.200	0.030	±0.005

Metric Dimensions (mm)

Fractional	Size		Expanded I.D. Minimum	Recovered I.D. Maximum	Wall Thickness	
	mm				Nom.	Tol.
3/32		2.36	2.36	1.42	0.20	±0.08
1/8		3.18	3.18	1.91	0.25	±0.08
3/16		4.78	4.78	2.92	0.25	±0.08
1/4		6.35	6.35	3.81	0.25	±0.08
3/8		9.53	9.53	5.72	0.31	±0.08
1/2		12.70	12.70	7.62	0.38	±0.10
3/4		19.05	19.05	11.43	0.51	±0.10
1		25.40	25.40	15.24	0.64	±0.13
1-1/2		38.10	38.10	22.86	0.76	±0.13
2		50.80	50.80	30.48	0.76	±0.13

COMPLIES WITH: AMS-DTL-I-23053/11 Class 2

COLOR: Supplied in natural unless otherwise specified. Custom Pantone colors or ZEUS standard colors available on request.

CUT PIECES: QUOTED ON REQUEST

CUSTOM SPECIFICATIONS AND TOLERANCES QUOTED UPON REQUEST



WWW.ZEUSINC.COM

FEP Roll Covers

HEAT SHRINKABLE EXTRUSIONS

ZEUS Roll Covers extend the life and reliability of rollers and improve product quality. A brief application of heat molds the cover snugly around the roll, forming a skin-tight, high-strength, impregnable jacket impervious to corrosive chemicals, solvents, acids, shock, abrasion, high temperatures, and moisture. They eliminate sticky build-up problems. With the use of a convenient heat source, such as a hot air gun, ZEUS Roll Covers can be quickly and easily shrunk onto the rolls. Cleaning can be done with a solvent or reagent.



For the printing, paper, textile, and food packaging industries, and others



- No sticking
- No picking
- Low maintenance
- Flexibility
- Excellent chemical resistance
- Handles delicate materials
- Saves labor costs
- Cuts cleaning time
- High temperature resistance

Dimensions (Inches)

Large Diameter

Ordered As Size	To Cover Roll Dia. Min.	To Cover Roll Dia. Max.
1-1/4	1.0	1.3
1-1/2	1.4	1.7
2	1.8	2.1
2-1/2	2.2	2.6
3	2.7	3.1
3-1/2	3.2	3.6
4	3.5	4.2
5	4.4	5.2
6	5.4	6.2
7	6.4	7.2

Small Diameter

Ordered As Size	To Cover Roll Dia. Min.	To Cover Roll Dia. Max.
1/2	.440	.550
5/8	.540	.700
3/4	.640	.800
7/8	.760	.950
1	.880	1.100

Metric Dimensions (mm)

Large Diameter

Ordered As Size	To Cover Roll Dia. Min.	To Cover Roll Dia. Max.
1-1/4	25.40	33.02
1-1/2	35.56	43.18
2	45.92	53.34
2-1/2	55.88	66.04
3	68.58	78.74
3-1/2	81.28	91.44
4	88.90	106.68
5	111.76	132.08
6	137.16	157.48
7	162.56	182.88

Small Diameter

Ordered As Size	To Cover Roll Dia. Min.	To Cover Roll Dia. Max.
1/2	11.18	13.97
5/8	13.72	17.78
3/4	16.26	20.32
7/8	19.30	24.13
1	22.35	27.94

WALL THICKNESS: .020" (.508mm) Nominal

COLOR: Natural. Custom colors available upon request.

Complete technical information provides helpful data to speed production and cut maintenance.



Heat Shrink Tubing Offering a Tight, Moisture-Resistant, Wear-Proof Encapsulation



- Outer tubing of PTFE shrinks for tight fit when heat is applied.
- Inner layer of FEP melts and flows to encapsulate parts.

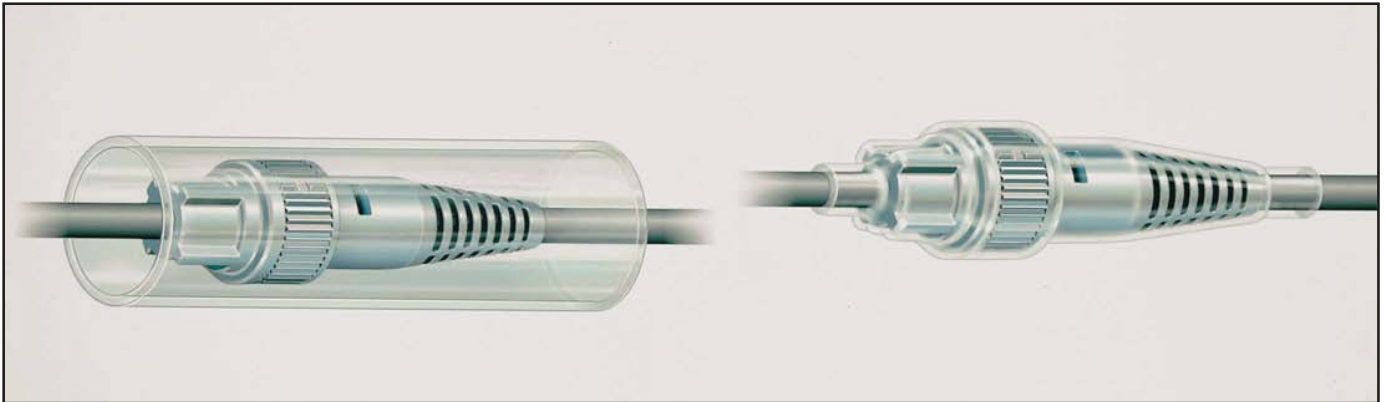

ZEUS Dual-Shrink® tubing of fluoropolymer PTFE/FEP is constructed with an exterior of heat shrink PTFE and an inner layer of FEP. It is easy to apply, and is designed to provide a tight, moisture-proof bond over wires, cables, connectors, splices, terminals, etc. The PTFE shrinks tightly over inserted parts when the covered section is heated, while the FEP melts and flows into a solid or near-

solid encapsulation with a fit so tight that it can withstand the most severe stresses involving pull or vibration. ZEUS Dual-Shrink® tubing provides all the outstanding electrical, chemical, and mechanical properties of PTFE including a service temperature up to 450°F/232°C. Custom specifications and tolerances quoted upon request.



WWW.ZEUSINC.COM

PTFE/FEP Dual-Shrink® Tubing

HEAT SHRINKABLE EXTRUSIONS



Dimensions (inches)

STANDARD WALL				LIGHTWEIGHT WALL			
Item No.	As Supplied I.D. Min.	Recovered Dim. I.D. Will Shrink To at Least	After Shrinking Total Wall Thickness-Norm.	Item No.	As Supplied I.D. Min.	Recovered Dim. I.D. Will Shrink To at Least	After Shrinking Total Wall Thickness-Norm.
ZDS-S-036	0.036	0.000	N/A	ZDS-L-065	0.065	0.000	N/A
ZDS-S-060	0.060	0.000	N/A	ZDS-L-115	0.115	0.045	0.015
ZDS-S-130	0.130	0.000	N/A	ZDS-L-130	0.130	0.060	0.015
ZDS-S-160	0.160	0.000	N/A	ZDS-L-180	0.180	0.065	0.015
ZDS-S-190	0.190	0.062	0.035	ZDS-L-190	0.190	0.070	0.015
ZDS-S-250	0.250	0.125	0.035	ZDS-L-240	0.240	0.150	0.020
ZDS-S-350	0.350	0.190	0.035	ZDS-L-350	0.350	0.210	0.025
ZDS-S-450	0.450	0.312	0.055	ZDS-L-480	0.480	0.315	0.032
ZDS-S-700	0.700	0.440	0.055	ZDS-L-700	0.700	0.500	0.040
ZDS-S-950	0.950	0.630	0.065	ZDS-L-1000	1.000	0.700	0.045

Metric Dimensions (mm)

STANDARD WALL				LIGHTWEIGHT WALL			
Item No.	As Supplied I.D. Min.	Recovered Dim. I.D. Will Shrink To at Least	After Shrinking Total Wall Thickness-Norm.	Item No.	As Supplied I.D. Min.	Recovered Dim. I.D. Will Shrink To at Least	After Shrinking Total Wall Thickness-Norm.
ZDS-S-036	0.91	0.000	N/A	ZDS-L-065	1.65	0.000	N/A
ZDS-S-060	1.52	0.000	N/A	ZDS-L-115	2.92	1.14	0.38
ZDS-S-130	3.30	0.000	N/A	ZDS-L-130	3.30	1.52	0.38
ZDS-S-160	4.06	0.000	N/A	ZDS-L-180	4.57	1.65	0.38
ZDS-S-190	4.83	1.57	0.89	ZDS-L-190	4.83	1.78	0.38
ZDS-S-250	6.35	3.18	0.89	ZDS-L-240	6.10	3.81	0.51
ZDS-S-350	8.89	4.83	0.89	ZDS-L-350	8.89	5.33	0.64
ZDS-S-450	11.43	7.92	1.40	ZDS-L-480	12.19	8.00	0.81
ZDS-S-700	17.78	11.18	1.40	ZDS-L-700	17.78	12.70	1.02
ZDS-S-950	24.13	16.00	1.65	ZDS-L-1000	25.40	17.78	1.14

PACKAGING: Standard 4ft lengths, unless otherwise specified.

Custom Pantone colors or ZEUS standard colors available on request.
Dual-Shrink Tubing is a ZEUS registered trademark.



ZEUS[®]

SPECIALTY PRODUCTS



SPECIALTY PRODUCTS

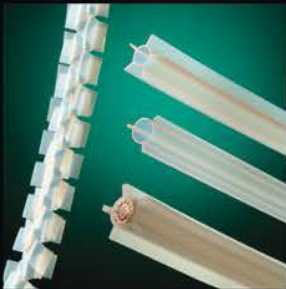



WWW.ZEUSINC.COM

PTFE Sub-Lite-Wall® Extruded & Heat Shrinkable Tubing

All Sub-Lite-Wall® is custom ordered

Dimensions (Inches)

EXTRUDED		HEAT SHRINK		
Inside Diameter Inches	Wall Thickness Inches	Expanded I.D. Min. Inches	Recovered I.D. Max. Inches	Recovered Wall Thickness Inches
0.0020	0.0020	0.020	0.008	0.0020
0.0025	0.0020	0.025	0.010	0.0020
0.0030	0.0020	0.030	0.012	0.0020
0.0040	0.0020	0.034	0.015	0.0020
0.0050	0.0030	0.038	0.018	0.0020
0.0060	0.0030	0.046	0.022	0.0020
0.0080	0.0030	0.050	0.027	0.0020
0.0100	0.0030	0.055	0.032	0.0020
0.0130	0.0030	0.060	0.039	0.0020
0.0160	0.0030	0.076	0.049	0.0020
0.0200	0.0020	0.093	0.061	0.0020
0.0250	0.0020	0.120	0.072	0.0020
0.0320	0.0020	0.150	0.089	0.0020
0.0400	0.0015	0.191	0.112	0.0020
0.0650	0.0015	0.240	0.141	0.0025
0.0730	0.0015			
0.0840	0.0015			
0.0980	0.0020			
0.1100	0.0020			
0.1620	0.0025			
0.2040	0.0035			
0.2580	0.0040			
0.3250	0.0050			

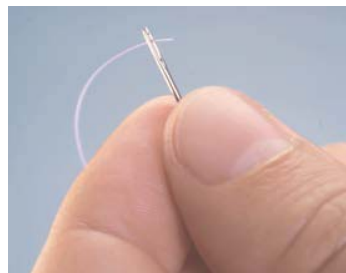

Now available in Sub-Lite-Wall® configurations with wall thicknesses down to .001 on many sizes. +/- .0005" (.013mm). Tolerances available in most sizes. Call us for more details.

ZEUS SUB-LITE-WALL® Tubing is available in both regular extruded micro-miniature dimensions, and in heat shrink versions. Inside diameters, outside diameters, and wall thicknesses are uniform throughout. **The dimensions and tolerances shown here are only a guide.** You can write your own specifications with the assurance that ZEUS can meet your requirements completely in either extruded or heat shrink version.